

Luminary Series

Vent-Free & Direct Vent Fireplaces



The Luminary Series... where superior performance and unique versatility are showcased in an ultramodern design. A masterpiece on fire, but a presence that represents luxury with or without the flame.

The look of tomorrow from Design Dynamics.



INNOVATION ON FIRE

Design Dynamics premieres two new linear fireplaces from the contemporary Luminary Series. Introducing the Linear Direct Vent Fireplace, Venice Lights and the Linear Vent-Free Fireplace System, Paris Lights.

These dynamic new products are offered in an amazingly chic and polished style with adaptability and versatility you haven't even thought of, yet.

DRAMATIC BEAUTY

Both fireplaces span 43" across and take on a modern oblong shape unlike any of our other units. Reflective black porcelain lined interior walls amplify the flame and boast the power of the fire. The crystal clear glass beads add sparkle to the burner and already dazzling yellow flames.

The lively blaze is highlighted by a glowing tray of embers and is innovatively accented with hallogen lighting. The lights shine through from underneath the glass stones to elegantly illuminate your fireplace. Now you can create ambiance with mood lighting whether the fire is burning or not.

This cutting edge design is far from traditional, yet all controls remain concealed so the finished look remains as clean and effortless as possible.



An elegant statement in an office, restaurant or lobby setting.



Venice Lights Direct Vent burners include ember material that extends the flame.



Accent Lighting illuminates your fireplace even when it's not burning. Operate hallogen lights with included remote control.

Customize your showpiece with colored stone accessories. Pebbles are available in Amber, Blue and Green (Shown Above) & Speckled Orange (Shown Left).



Paris Lights Vent-Free Fireplaces can instantly convert to See-Thru models so you can enjoy the flame from two rooms at once.

VERSATILITY

This standout series is beyond accommodating when it comes to application. Both swanky hearths have the ability to transform to see-thru models. Simply remove the back panel on your Vent-Free linear and instantly convert your Paris Lights fireplace to a multi-view model. The Direct Vent, Venice Lights, has an optional accessory see-thru glass door kit. Replace the back panel with the glass door to enjoy this focal point from two vantage points.

We've taken the Venice Lights to the next level! Once you've installed a see-thru glass door, you can opt for an even more appealing feature, allowing you to experience this luminary from the warmth of your home or in your backyard retreat. Introducing our first ever accessory glass door kit for Indoor/Outdoor applications. This unique accessory includes a tempered glass door and weather-proof frame allowing you to enjoy one side of your see-thru from your outside patio.

ABSOLUTE FEATURES

All Luminary Series models include some amazing features. Sleek black porcelain coated reflective panels line the inner walls and accentuate the yellow flames. The direct vent see-thru doors are made of ceramic glass which radiates the heat. The fireplace features an adjustable flame and electronic ignition for your convenience. Mood lighting and remote control are standard and clear smooth pebbles complete the look.

FINISHING YOUR UNIT

Unlike the other guys who require trim and faces to hide openings and allow for heat shields, Design Dynamics fireplaces can be finished right up to the edge. Be bold and choose from our Decorative Face Trim Frame offered in black, aged silver or aged copper. Or go with your own custom non-combustible material such as stone veneer, marble or granite.



Convert your Luminary fireplace into a See-Thru model. A choice solution for adding a modern feel to two rooms at once.



Upgrade your Venice Lights Direct Vent to a See-Thru Model. Take it to the next level by adding our Indoor/Outdoor Accessory See-Thru Door Kit.

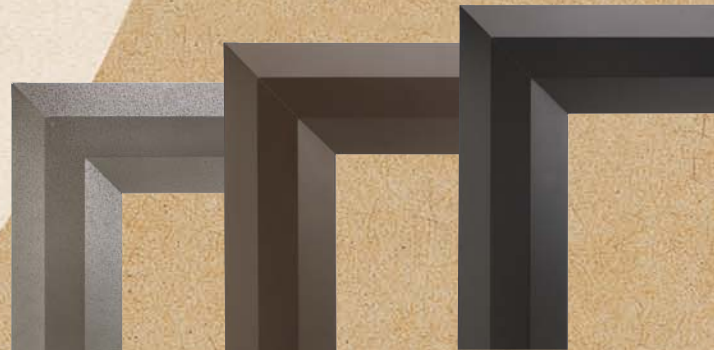

Decorative Face Trims are available in Aged Silver, Aged Copper and Black.



Luminary Series 43" Linear Fireplaces

Name	Model No.	Application	Fuel Type	BTU's	Shpg. Weight	Cubes
Paris Lights	LVF43NR	Vent-Free	Natural	40,000	225.0 lbs.	23
Paris Lights	LVF43PR	Vent-Free	Propane	40,000	225.0 lbs.	23
Venice Lights	LDV43NE	Direct Vent	Natural	26,000 - 41,000	245.0 lbs.	23
Venice Lights	LDV43PE	Direct Vent	Propane	25,000 - 39,000	245.0 lbs.	23

Vent-Free Dimensions

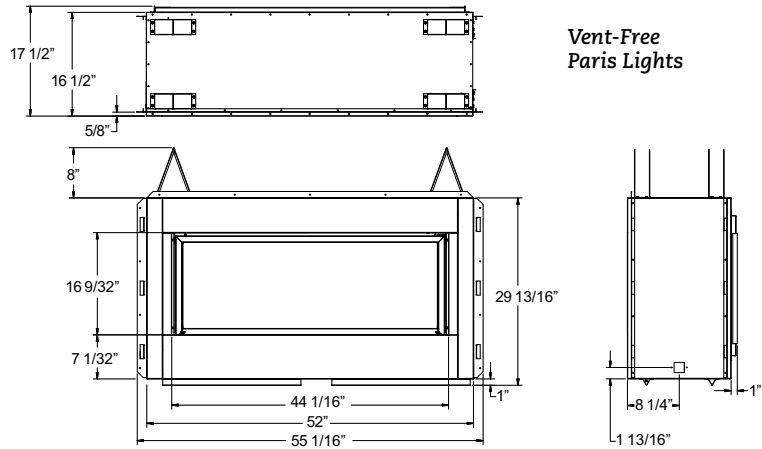

Direct Vent Dimensions

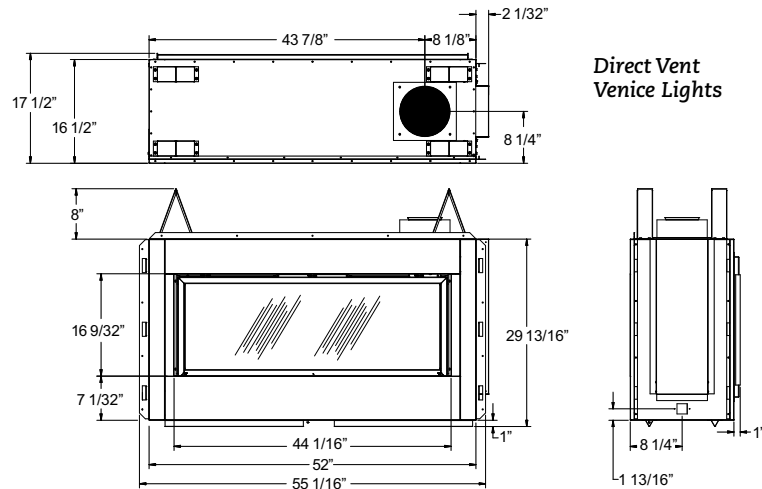

Printed in U.S.A.



www.fmiproducts.com